

# Blazin Fiddles Stage Spec

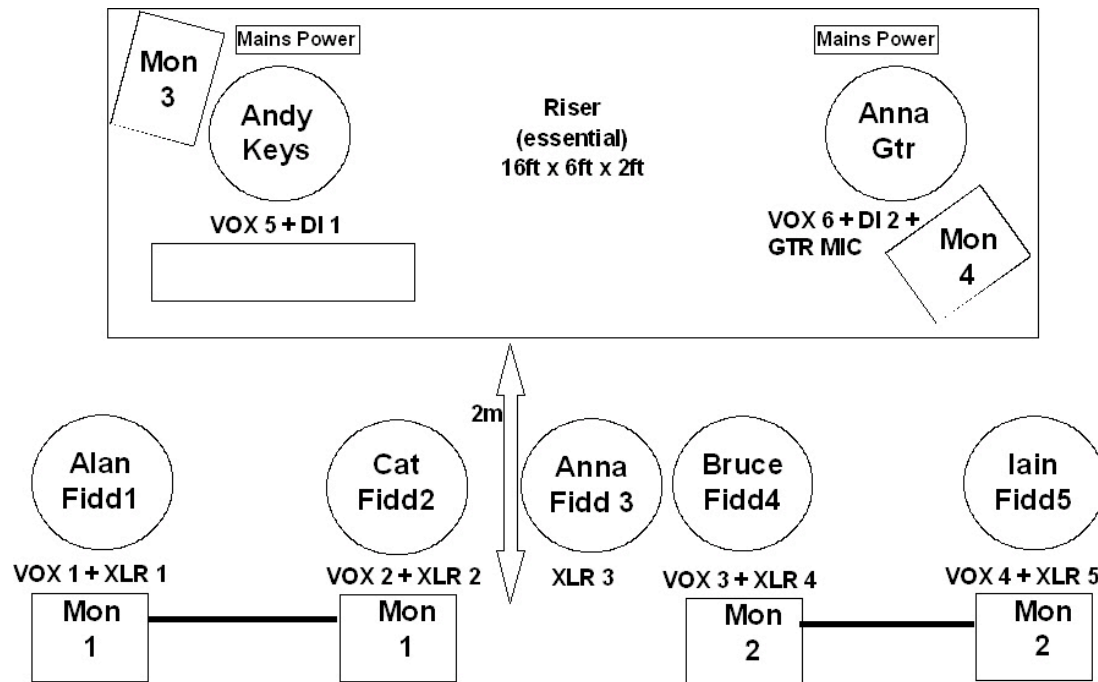

## Channel List-

<ol style="list-style-type: none"> <li>1. Keys (DI 1)</li> <li>2. Gtr (DI 2)</li> <li>3. Gtr Mic (condenser)</li> <li>4. Alan Fiddle (XLR 1))</li> <li>5. Catriona (XLR 2)</li> <li>6. Anna Fiddle (XLR 3)</li> <li>7. Bruce Fiddle (XLR 4)</li> <li>8. Iain Fiddle (XLR 5)</li> <li>9. Alan Vox 1</li> <li>10. Catriona Vox 2</li> <li>11. Bruce Vox 3</li> <li>12. Iain Vox 4</li> <li>13. Andy Vox 5</li> <li>14. Marc Vox 6</li> </ol>	<p>PA must be of suitable size for the venue and be in stereo. Set up must be at least 2 way with subs and be able to reproduce sound clearly and undistorted. Desk must be placed towards the rear of the venue, in the centre of the room if possible, not in a box or behind glass and have at least six aux sends for four monitors, (if monitors are sent from FOH), and two effects (one reverb and one delay). Please also provide four compressors. If possible each member of the band will get their own monitor send, if not this stage plan is <b>absolute minimum</b>. Each monitor send and left and right send should have a 32 band graphic equaliser in line, controlled from the FOH position. All gear should be of professional quality, i.e. Midas, Soundcraft, Allen and Heath, BSS, Drawmer, TC, Klark Technik, Shure, etc...etc. Analogue desks are preferred. Please get in touch at least one week prior to the concert if a Digital desk is going to be provided. All sound and stage gear must be supplied at no cost to the performer.</p>
--	---

For all Tech enquiries please contact Gareth Ince on [07828 713568](tel:07828713568)  
or [garethince@hotmail.com](mailto:garethince@hotmail.com)